

Optoelectronics Components Data Sheet

■ DE-0784

622Mbps PIN-preamplifier Coaxial Module

Description

DE-0784 is a 622Mbps, optical receiver module of coaxial pigtail type. This module consists of an InGaAs PIN photodiode (PD) with a trans-impedance amplifier (TIA), a single-mode fiber and a coaxial package. This module is suitable for building digital optical transmission systems up to 622Mbps.

Features

- ◆ Data rate : 622Mbps
- ◆ Optical sensitivity : -31dBm
- ◆ Differential output
- ◆ Built-in TIA
- ◆ Hermetically sealed PIN-TIA device
- ◆ YAG laser spot welding for high reliability
- ◆ Coaxial Package
- ◆ -40 to +85 °C operating temperature range

Applications

- SONET OC-12/SDH STM4 applications
- Digital transmission systems

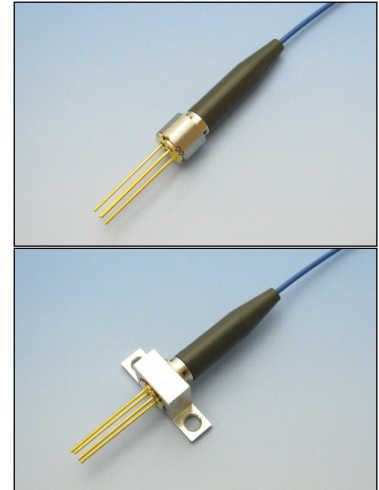

Absolute Maximum Ratings

(Tc=25°C, unless otherwise specified)

Parameter	Symbol	Ratings	Unit	Conditions
Power supply voltage	Vcc	4.5	V	---
Optical Input power	Pin	10	dBm	---
Storage temperature	Tstg	-40 ~ +85	°C	---
Operating temperature	Tc	-40 ~ +85	°C	---
Soldering temperature	Ts	260	°C	10sec, >2mm

Electrical and Optical Characteristics

(Tc=-40 to 85°C, unless otherwise specified)

Parameter	Symbol	Conditions	Min.	Typ.	Max.	Unit
Power supply voltage	Vcc	---	3	3.3	3.6	V
Power supply current	Icc	---	---	30	45	mA
Output voltage (Differential)	Vout	RL>500Ω	---	---	1000	mVpp
Responsivity (Differential)	R	λp=1550nm, RL>500Ω Pin= -30dBm(Ave.), 10MHz	16	26	---	kV/W
Bandwidth	BW	RL=50Ω, Pin=-30dBm, -3dB	340	400	---	MHz
Operating bit rate	fop	---	---	---	622	Mbps
Output impedance	Rout	Single ended	30	45	60	Ω
Sensitivity	Prmin	fop=622Mbps, ExR=10dB λp=1550nm, BER=10 ⁻¹⁰ PRBS 2 ²³ -1 NRZ	---	-31	---	dBm

Outline Drawings

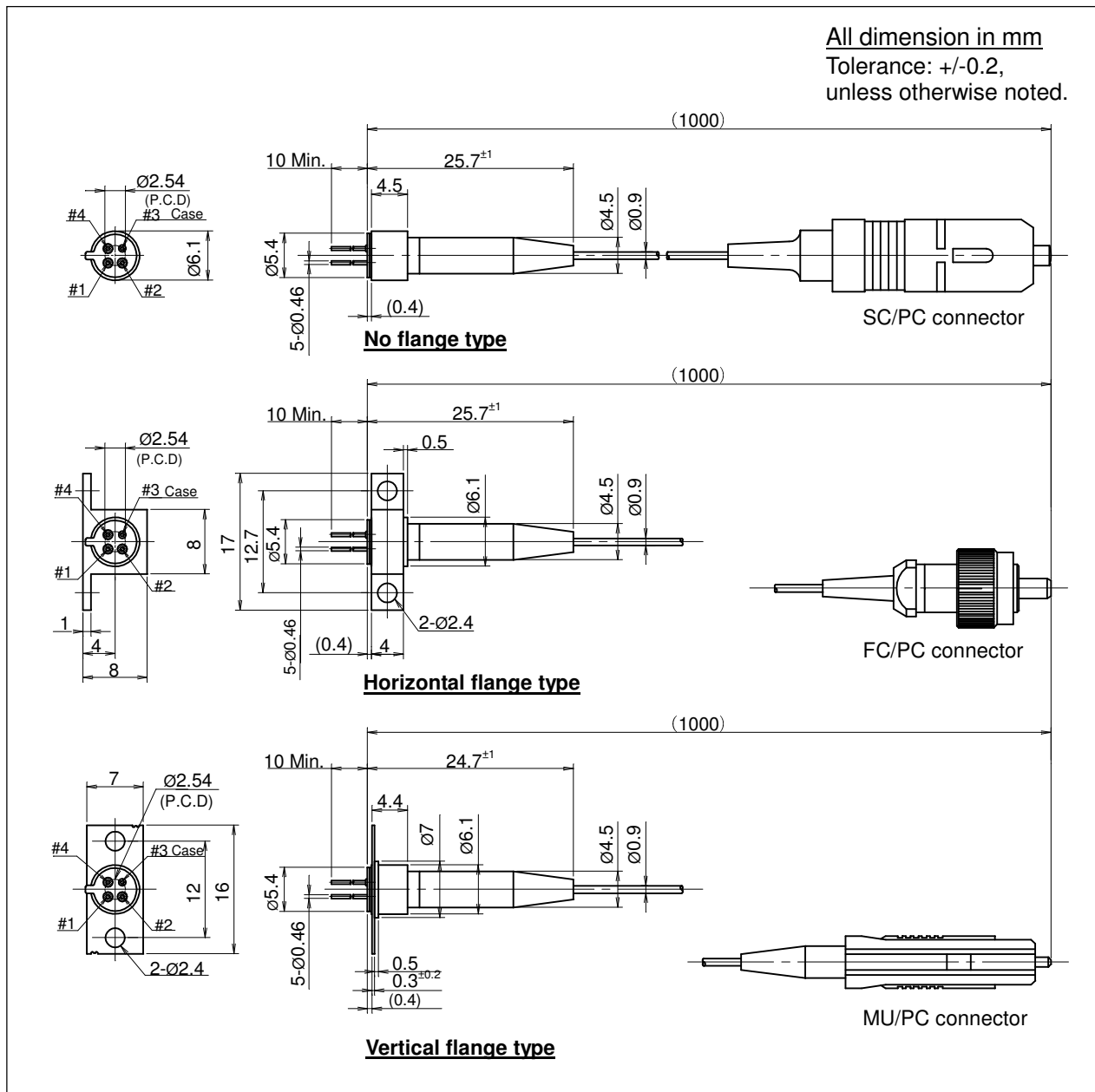

Pin configuration

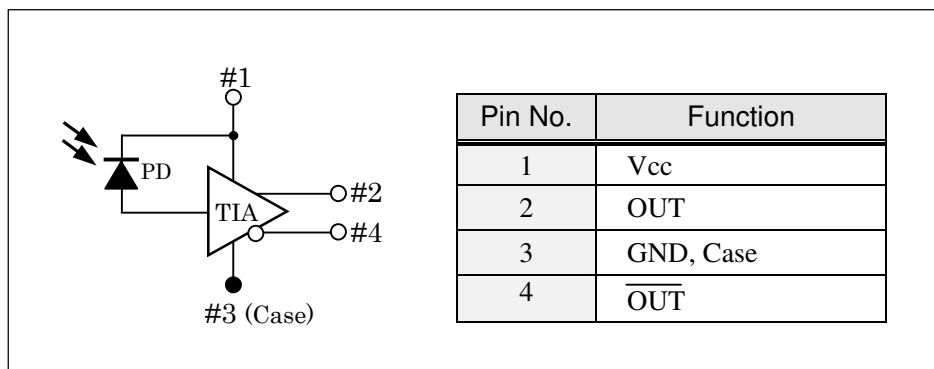

Optical Fiber Characteristics

Parameter	Min.	Typ.	Max.	Unit
Fiber type	Single mode			---
Mode field diameter	8	9	10	μm
Clad diameter	123	125	127	μm
Concentricity error	---	---	1	μm
Cladding non-circularity	---	---	2	%
Mode field non-circularity	---	---	6	%
Cut off wavelength	1270	---	---	nm
Jacket diameter	0.8	0.9	1	mm
Bending Radius	20	---	---	mm
Tensile strength fiber case	5	---	---	N
Length	---	(1000)	---	mm
Connector	FC type / SPC			
	SC type / SPC			
	MU type / SPC			

Ordering information

DE-0784-□□

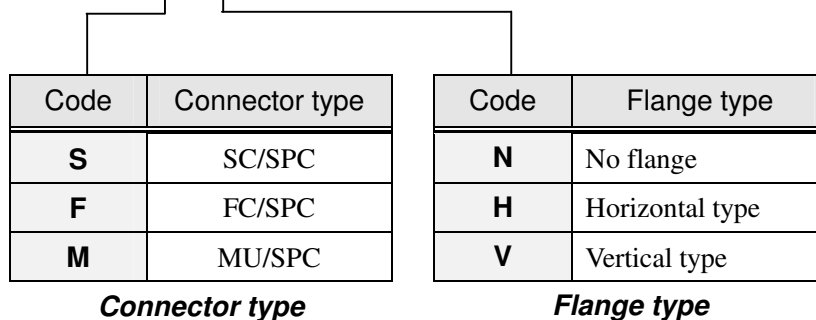

OPTOHUB Co., Ltd.

305 Live Tower Musashi Urawa
 7-6-8 Bessho, Minami-ku, Saitama-shi
 Saitama, 336-0021 JAPAN

URL : <http://www.optohub.com>
 E-mail : info@optohub.com
 TEL : +81-48-844-8899
 FAX : +81-48-844-8902