

Optoelectronics Components Data Sheet

■ DE-0494

1310nm, 150mW FP Laser Diode Coaxial Module for OTDR

Description

DE-0494 is 1310nm high-power pulse drive laser diode (LD) modules of coaxial pigtail type. This module consists of a multi quantum well Fabry Perot (MQW FP) LD, a monitor photo diode (PD), a single-mode fiber and a coaxial package. This module is suitable for OTDR applications.

Features

- ◆ Fiber output power : 150mW Min. (Pulse drive)
- ◆ MQW FP LD structure
- ◆ Includes monitor PD
- ◆ Hermetically sealed LD device
- ◆ YAG laser spot welding for high reliability
- ◆ Coaxial package

Applications

- OTDR systems
- Optical measuring instruments

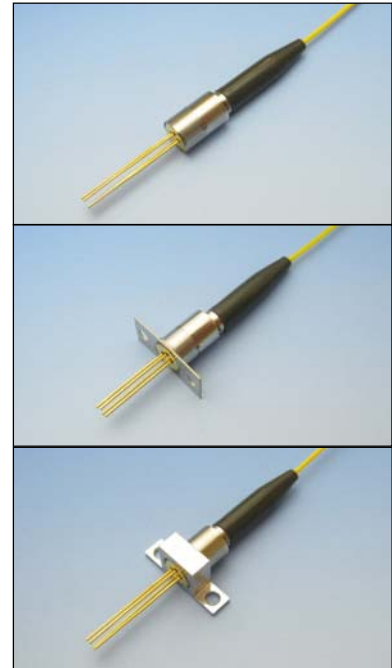

Absolute Maximum Ratings

(Tc=25°C, unless otherwise specified)

Parameter	Symbol	Ratings	Unit	Conditions
Peak fiber output power	Pf	170	mW	(*1)
LD reverse voltage	V _{RL}	2	V	(*1)
LD forward current	I _f	1000	mA	(*1)
Monitor PD Reverse voltage	V _{RP}	15	V	---
Monitor PD Forward current	I _{FP}	10	mA	---
Monitor PD Reverse current	I _{RP}	5	mA	---
Storage temperature	T _{stg}	-40 ~ +85	°C	---
Operating temperature	T _c	-20 ~ +60	°C	---
Soldering temperature	T _s	260	°C	10sec, >2mm

Note : (*1) Pulse driving conditions ; 10μsec pulse width and 1% duty

Electrical and Optical Characteristics

(Tc=25°C, unless otherwise specified)

Parameter	Symbol	Conditions	Min.	Typ.	Max.	Unit
Fiber output power	Pf	I _{op} =800mA (peak), (*2)	150	---	---	mW
Threshold current	I _{th}	(*2)	---	25	60	mA
Operation current	I _{op}	Pf=150mW, (*2)	---	650	800	mA
Operation voltage	V _{op}	Pf=150mW, (*2)	---	---	3	V
Center wavelength	λ _c	Pf=150mW, RMS, (*2)	1295	1310	1320	nm
Spectrum width	Δλ	Pf=150mW, RMS σ, -20dB, (*2)	---	---	10	nm
Monitor PD output current	I _m	V _{RP} =5V, Pf=5mW, CW	15	---	---	μA
Monitor PD dark current	I _d	V _{RP} =5V	---	---	50	nA
Tracking Error	TE	CW, I _m (@Tc=25°C) =constant	-1	---	1	dB

Note : (*2) Pulse driving conditions ; 10μsec pulse width and 1% duty

Outline Drawings

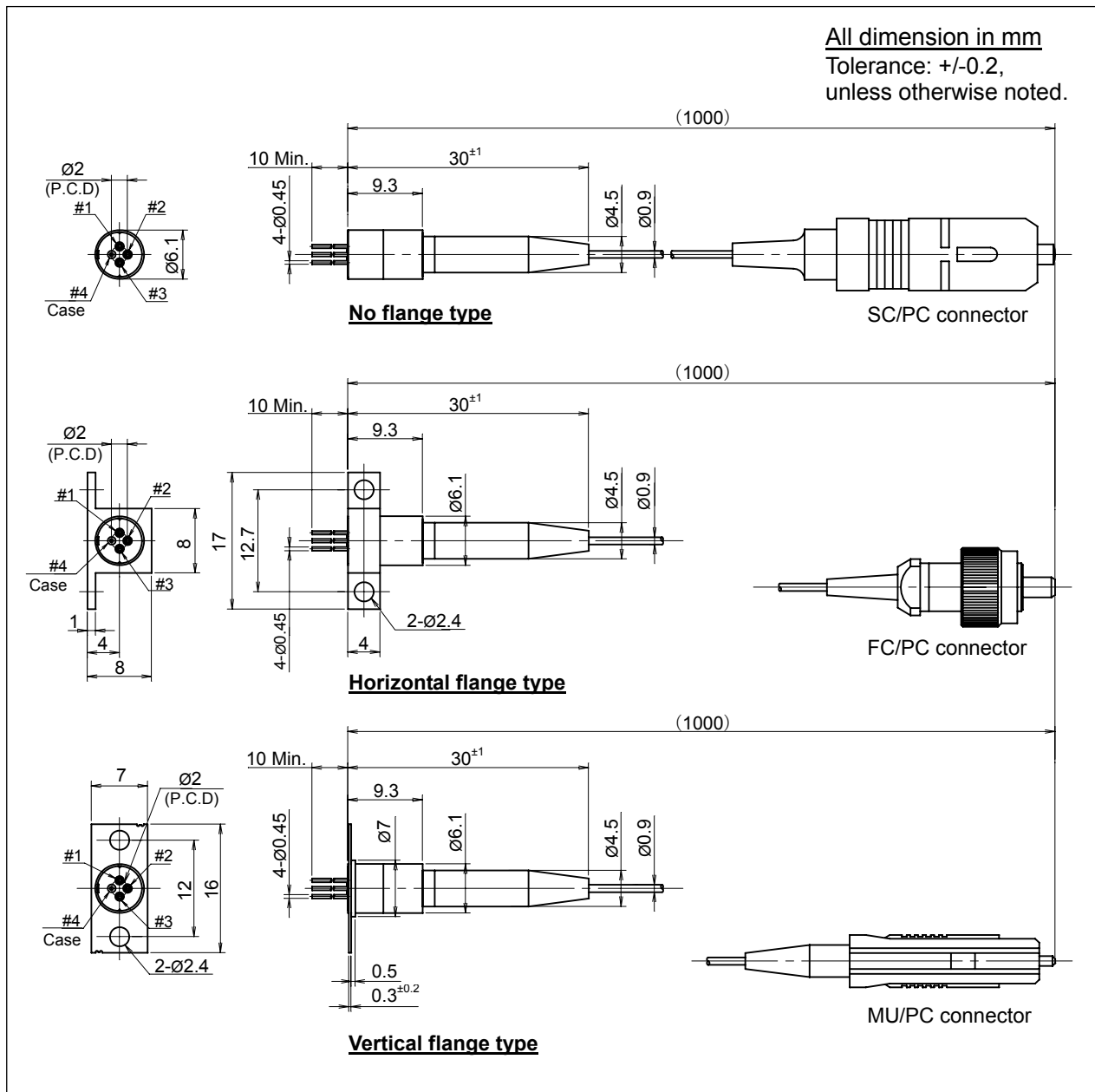

Pin configuration

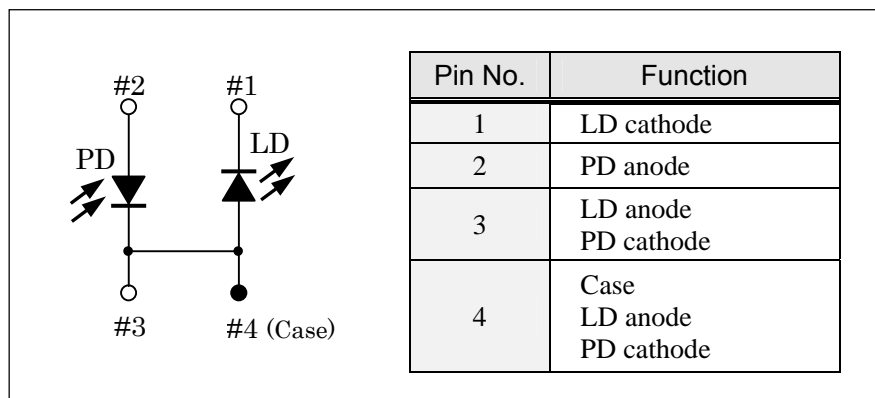

Optical Fiber Characteristics

Parameter	Min.	Typ.	Max.	Unit
Fiber type	Single mode			---
Mode field diameter	8	9	10	μm
Clad diameter	123	125	127	μm
Concentricity error	---	---	1	μm
Cladding non-circularity	---	---	2	%
Mode field non-circularity	---	---	6	%
Cut off wavelength	1270	---	---	nm
Jacket diameter	0.8	0.9	1	mm
Bending Radius	20	---	---	mm
Tensile strength fiber case	5	---	---	N
Length	---	(1000)	---	mm
Connector	FC type / SPC			
	SC type / SPC			
	MU type / SPC			

Ordering information

DE-0494-□□

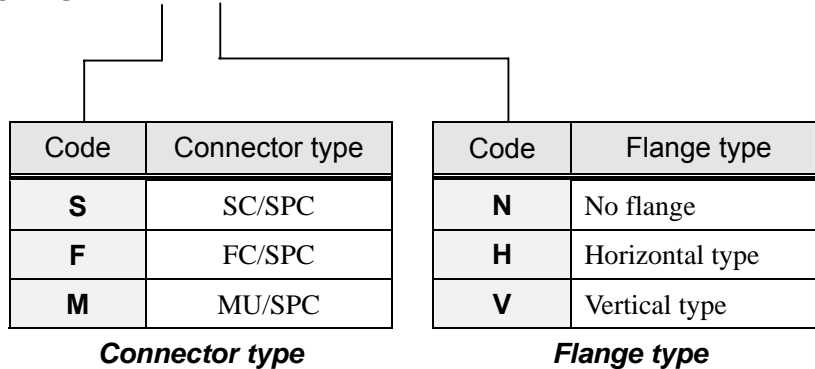

OPTOHUB Co., Ltd.

305 Live Tower Musashi Urawa
 7-6-8 Bessho, Minami-ku, Saitama-shi
 Saitama, 336-0021 JAPAN

URL : <http://www.optohub.com>
 E-mail : info@optohub.com
 TEL : +81-48-844-8899
 FAX : +81-48-844-8902

All specifications described herein are subject to change without notice.

Copyright 2008 OPTOHUB Co., Ltd.