

Optoelectronics Components Data Sheet

■ DE-0780

1550nm, 2mW FP Laser Diode Coaxial Module

Description

DE-0780 series are 1550nm laser diode (LD) modules of coaxial pigtail type. These modules consist of a multi quantum well Fabry Perot (MQW FP) LD, a monitor photo diode (PD), a single-mode fiber and a coaxial package. These modules are suitable for building ~1.25Gbps transmission system.

Features

- ◆ Fiber output power : 2mW Min.
- ◆ MQW FP structure
- ◆ Hermetically sealed LD devices
- ◆ YAG laser spot welding for high reliability
- ◆ Coaxial package
- ◆ -40 to +85 °C operating temperature range

Applications

- ~1.25Gbps transmission system

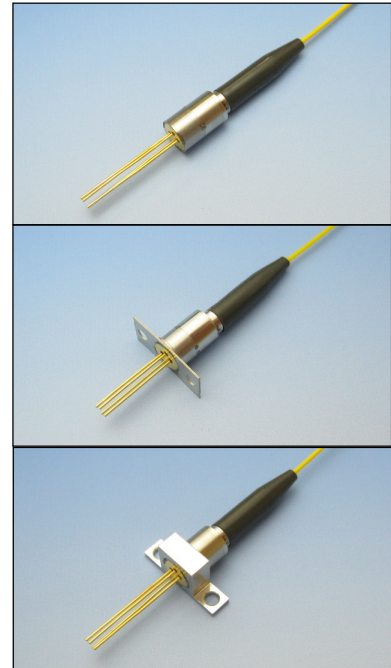

Absolute Maximum Ratings

(Tc=25°C, unless otherwise specified)

Parameter	Symbol	Ratings	Unit	Conditions
Fiber output power	Pf	6	mW	CW
LD reverse voltage	V _{RL}	2	V	---
LD forward current	If	150	mA	---
Monitor PD Reverse voltage	V _{RP}	20	V	---
Monitor PD Forward current	I _{FP}	2	mA	---
Storage temperature	T _{stg}	-40 ~ +100	°C	---
Operating temperature	T _c	-40~ +85	°C	---
Soldering temperature	T _s	260	°C	10sec, >2mm

Electrical and Optical Characteristics

(Tc=25°C, unless otherwise specified)

Parameter	Symbol	Conditions	Min.	Typ.	Max.	Unit
Fiber output power	Pf	CW	2	4	---	mW
Threshold current	I _{th}	CW	3	10	20	mA
Operation current	I _{op}	CW, Pf=2mW	10	30	50	mA
Operation voltage	V _{op}	CW, Pf=2mW	---	---	1.5	V
Center wavelength	λ _c	CW, Pf=2mW, RMS	1520	1550	1580	nm
Spectrum width	Δλ	CW, Pf=2mW, RMSσ, -20dB	---	1.5	3	nm
Rise & Fall time	t _r , t _f	10-90%, I _b =I _{th} , Pf=2mW	---	0.3	0.7	ns
Monitor PD output current	I _m	V _{RP} =1V, Pf=2mW	100	---	1000	μA
Monitor PD dark current	I _d	V _{RP} =10V	---	---	100	nA
Monitor PD Capacitance	C _t	V _{RP} =10V	---	---	20	pF
Tracking Error	TE	CW, I _m (@Tc=25°C) =constant	-1	---	1	dB

Outline Drawings

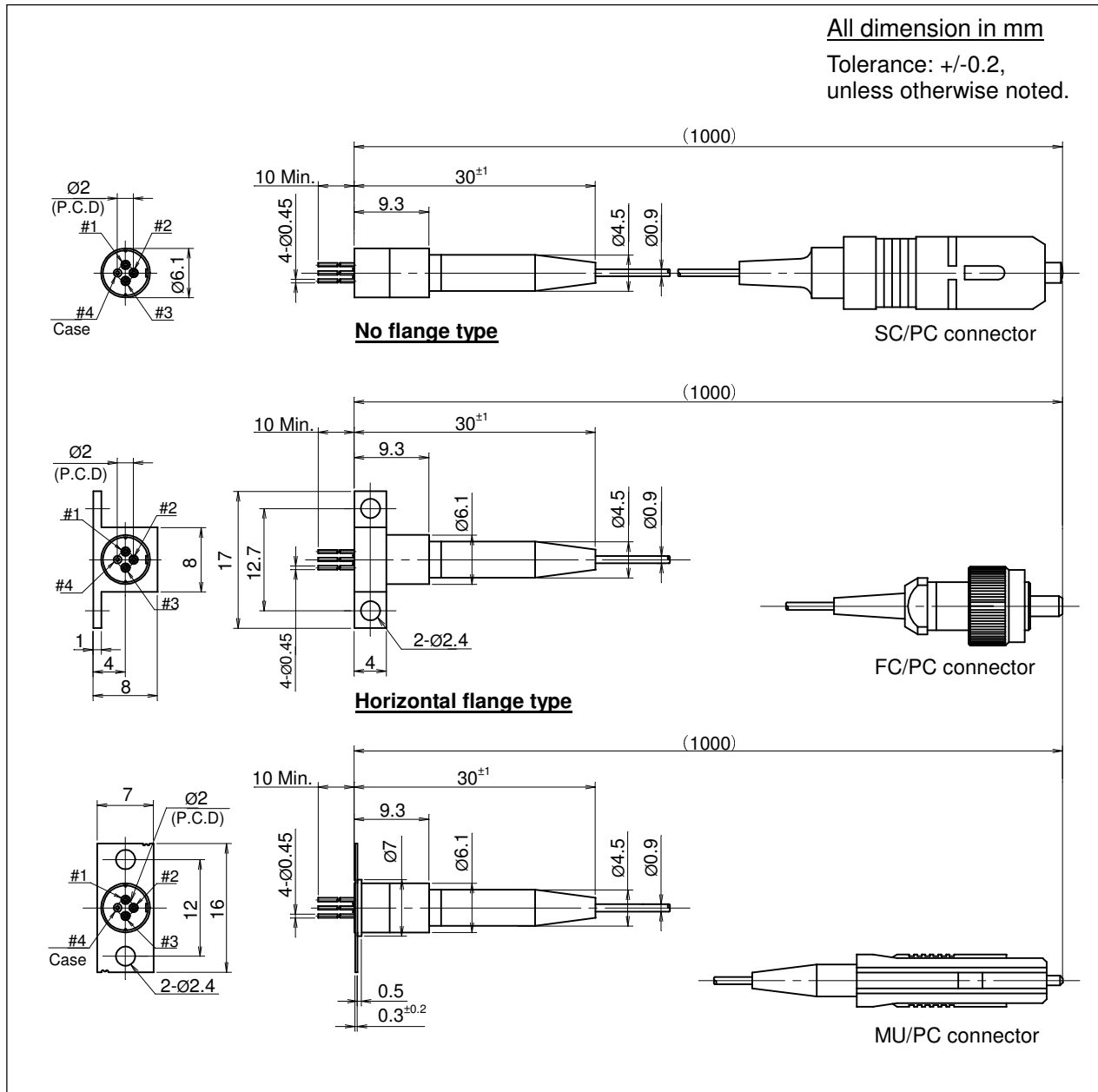

Pin configuration

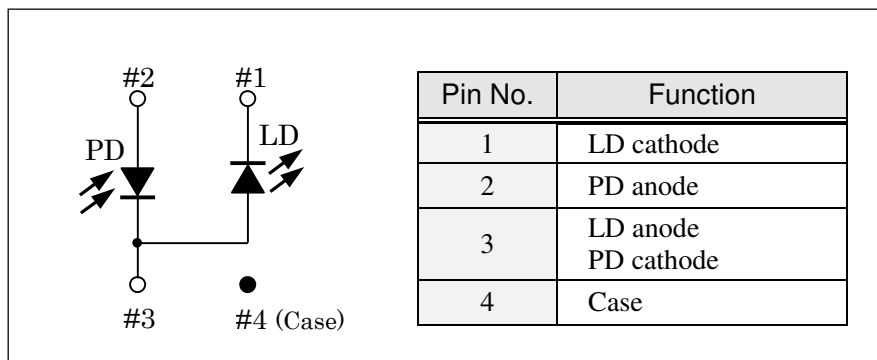

Optical Fiber Characteristics

Parameter	Min.	Typ.	Max.	Unit
Fiber type	Single mode			---
Mode field diameter	8	9	10	μm
Clad diameter	123	125	127	μm
Concentricity error	---	---	1	μm
Cladding non-circularity	---	---	2	%
Mode field non-circularity	---	---	6	%
Cut off wavelength	1270	---	---	nm
Jacket diameter	0.8	0.9	1	mm
Bending Radius	20	---	---	mm
Tensile strength fiber case	5	---	---	N
Length	---	(1000)	---	mm
Connector	FC type / SPC			
	SC type / SPC			
	MU type / SPC			

Ordering information

DE-0780-□□

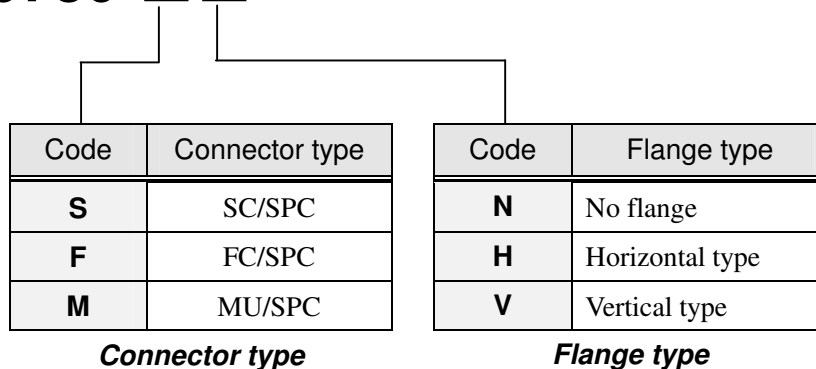

OPTOHUB Co., Ltd.

305 Live Tower Musashi Urawa
 7-6-8 Bessho, Minami-ku, Saitama-shi
 Saitama, 336-0021 JAPAN

URL : <http://www.optohub.com>
 E-mail : info@optohub.com
 TEL : +81-48-844-8899
 FAX : +81-48-844-8902